

MB FRIGO

ARCTICO₂ REFRIGERATION UNITS



Commercial refrigeration units with natural refrigerant CO₂

ArctiCO₂ provide energy-efficient cooling, top quality control of products and raw materials and energy savings. They are an ideal solution for use at gas stations, restaurants, cafes, bakeries, butcher shops and similar facilities. The compact design ensures easier handling and installation. Installation is applicable in all climate conditions thanks to its corrosion resistant design.

**CHILLING
YOUR WORLD**
SINCE 1981

Awareness of the need for environmental protection increases by the day. As one of the measures aimed at reducing greenhouse gas emissions, the F-Gas regulation was introduced in 2015, which limits and prohibits the use of HFC refrigerants in air conditioning and refrigeration units. At the same time, the use of natural refrigerants is encouraged, one of which is CO₂. Carbon dioxide is a suitable replacement for existing refrigerants due to its characteristics such as ODP= 0 and GWP = 1. An additional advantage of carbon dioxide is its low price and easy availability, which makes it an ideal replacement for the existing HFC refrigerants.

APPLICATION IN MT UNITS

For the application in MT units, we have developed CO₂ condensation units which can operate in subcritical and transcritical areas. High efficiency of the compressor is achieved with a BLDC compressor controller that regulates the rotation speed and ensures the required cooling capacity of the compressor.

APPLICATION IN LT UNITS

For the application in LT units, we have developed CO₂ condensing units that operate in subcritical and transcritical areas. The chiller is powered by a two-stage semi-hermetic compressor.

ARCTICO₂ AG MT

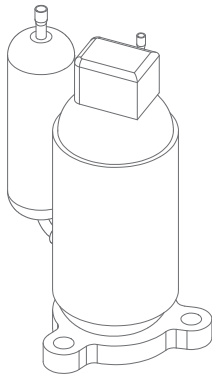

MB Frigo has developed 4 models with different cooling functions in two dimensional sizes. Condensing units are designed to work in warm climates where the air temperature can reach up to +46 °C. Also, the evaporation working range spans from -15 °C to +5 °C.

Specially designed, air-cooled gas cooler of curved design, equipped with continuously regulated EC fans, which maintain pressure in a narrow area and are working almost silently. Thanks to this curved design of the gas cooler, the unit is compact, small in dimensions and has a small floor plan area.

In cooperation with the company CAREL, we adapted the control software especially for our units. With a simple local control, network management of units is also possible, i.e. establishment of remote monitoring and control of all stored parameters, thus fulfilling the HACCP requirements.

ARCTICO₂ AG LT

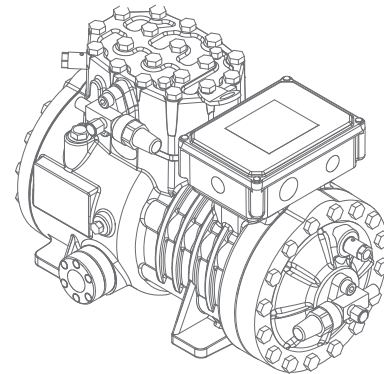

MB Frigo has developed 5 models with different cooling functions in two dimensional sizes. The evaporation working range spans from -30° C to -25° C. Smaller LT units also use an air-cooled curved gas cooler, which is equipped with a continuously regulated EC fan, which maintains pressure in a narrow area and are working almost silently. Thanks to this curved design of the gas cooler, the unit is compact, small in dimensions and has a small floor plan area. The version of the LT unit with two fans is also cooled by EC fans. Therefore, even stronger refrigeration units are designed for quiet operation.

Local and network management of units, i.e. remote monitoring and control of all parameters, is also enabled on LT units.

▶ NOMENCLATURE:

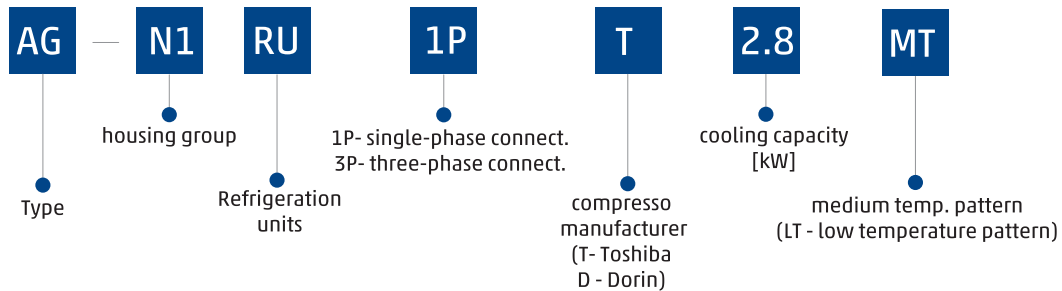

ARCTICO₂ AG MT

ARCTICO₂ AG LT

	ARCTICO ₂ AG MT	ARCTICO ₂ AG LT
BASIC EQUIPMENT	<ul style="list-style-type: none"> • hermetic rotary compressor • gas cooler with EC fan • liquid receiver • HPV and RPRV valves • safety valve up to 80 bar • filter-drier • slight glass • HP compressor protective pressure switch • magnetic valve pressure equalization to protect the compressor at its start • check valve on the pressure side of the compressor 	<ul style="list-style-type: none"> • semi-hermetic two-stage piston compressor • gas cooler / intercooler with EC fan • liquid receiver • HPV and RPRV valves • safety valve up to 80 bar • filter-drier • slight glass • HP compressor protective pressure switch • oil separator with heater (+ oil filter, solenoid valve, inspection glass)
CONTROLLER	<ul style="list-style-type: none"> • Carel Hecu CO₂ 	<ul style="list-style-type: none"> • Carel pRack 100T

▶ DEVICE DATA:

MT MODEL	name	ArctiCO ₂ 30	ArctiCO ₂ 45	ArctiCO ₂ 67	ArctiCO ₂ 100
		type	AG-N1RU1PT2.8MT	AG-N2RU1PT4.2MT	AG-N2RU1PT6MT
Compressor	type	DY30N1F-10FU	DY45N1F-10FU	DY67L1F-10FU	RY100L1F-10FU
	power supply	230 V/1~/50 Hz			400 V/3~/50 Hz
Max. current		12,5 A	18 A	24 A	18 A
Cooling capacity ¹	min. (25 rps)	0,7 kW	1 kW	1,5 kW	2,25
	max. (100 rps)	2,8 kW	4,2 kW	6 kW	9 kW
Liquid tank	PS ²	80 bar			
	PED	II			
Fan	type	1 x ø450mm (EC)			2 x ø450mm (EC)
Connecting pipes	φ SL	3/8"	3/8"	1/2"	5/8"
	φ LL	3/8"	3/8"	1/2"	1/2"
PS	high/medium/low	120/80/80 bar			

1 evaporation temperature -7°C, temperature at the gas cooler exit +35°C, total superheating 10K liquid subcooling 0K

2 maximum allowed pressure

IT MODEL	name	ArctiCO ≥300	ArctiCO ≥350	ArctiCO ≥360	ArctiCO ≥1200	ArctiCO ≥1500
		type	AG-N4RU3PD1.6IT	AG-N4RU3PD2IT	AG-N4RU3PD2.5IT	AG-N6RU3PD9IT
Compressor	type	CD2S300	CD2S350	CD2S360	CD2S1200	CD2S1500
	power supply	400 V/3~/50 Hz				
Max. current		6,0	7,3	7,5	28,0	34,0
Cooling capacity ³		1.6 kW	2 kW	2.5 kW	9 kW	12 kW
Liquid tank	PS ⁴	90 bar				
	PED	II				
Fan	tip	1 x ø500 mm (EC)			2 x ø500 mm (EC)	
Connecting pipes	φSL	3/8"	3/8"	3/8"	3/4"	7/8"
	φLL	3/8"	3/8"	3/8"	1/2"	1/2"
PS ⁴	high/medium/low	120/80/80 bar				

3 evaporation temperature -7°C, temperature at the gas cooler exit +35°C, total superheating 10K liquid subcooling 0K

4 maximum allowed pressure

- Te evaporation temperature
- Ta ambient temperature
- Pmax maximum electrical power
- Imax maximum electric current
- φ SL suction pipe
- φ LL liquid pipe

▶ REFRIGERANT UNIT:

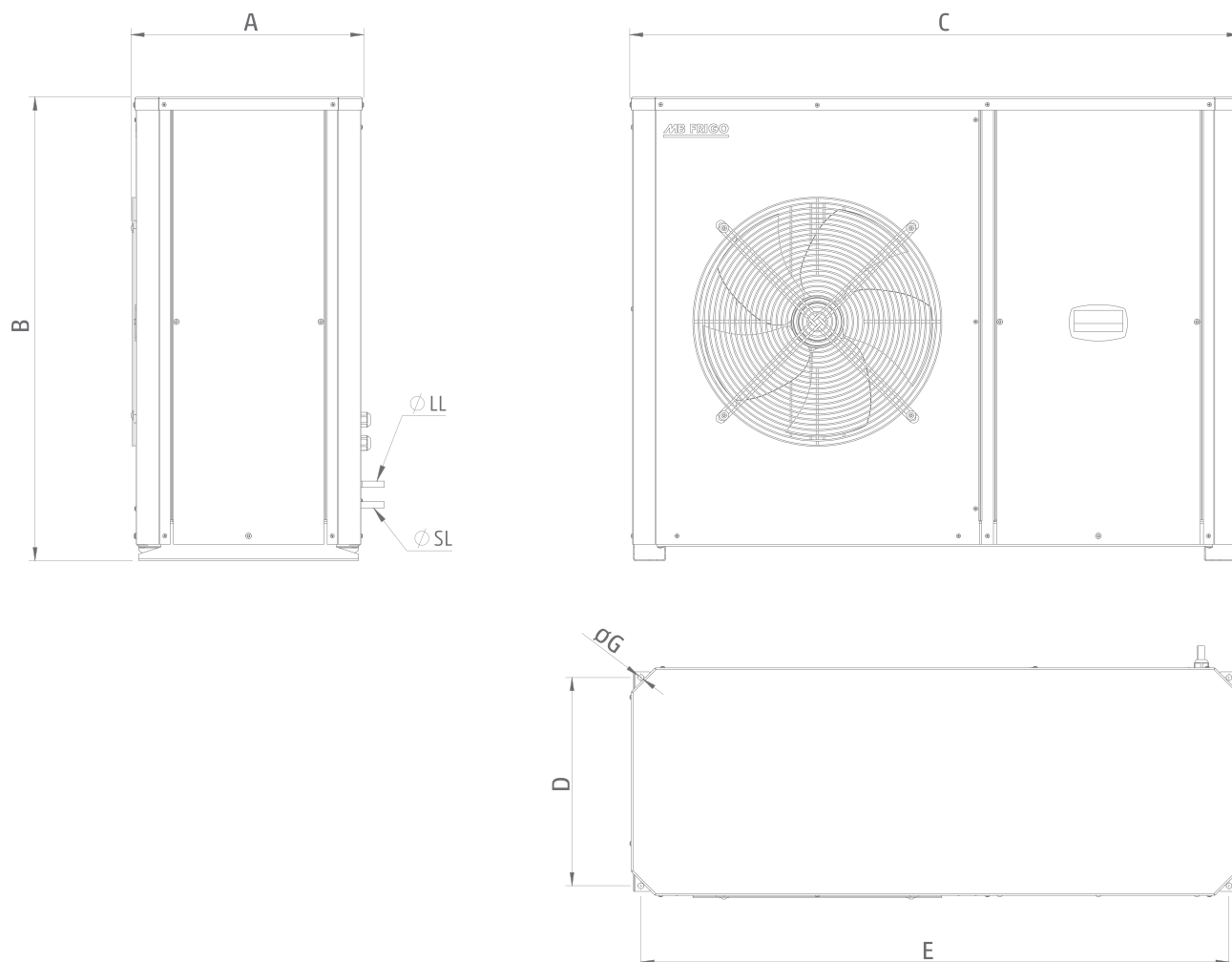

Refrigeration unit		Dimensions [mm]						Weight ⁴
MT Model	Type	A	B	C	D	E	G	[kg]
ArctiCO ₂ 30	AG-N1RU1PT2.8MT	448	893	1176	400	1133	11	105
ArctiCO ₂ 45	AG-N2RU1PT4.2MT	448	893	1176	400	1133	11	120
ArctiCO ₂ 67	AG-N2RU1PT6MT	448	893	1176	400	1133	11	121

Refrigeration unit		Dimensions [mm]						Weight ⁴
IT Model	Type	A	B	C	D	E	G	[kg]
ArctiCO ₂ 300	AG-N4RU3PD1.6IT	593	890	1351	516	1310	11	231
ArctiCO ₂ 350	AG-N4RU3PD2IT	593	890	1351	516	1310	11	231
ArctiCO ₂ 360	AG-N4RU3PD2.5IT	593	890	1351	516	1310	11	231

⁴ Weight of units includes protective housing, power supply and protection.

► REFRIGERATION UNIT:

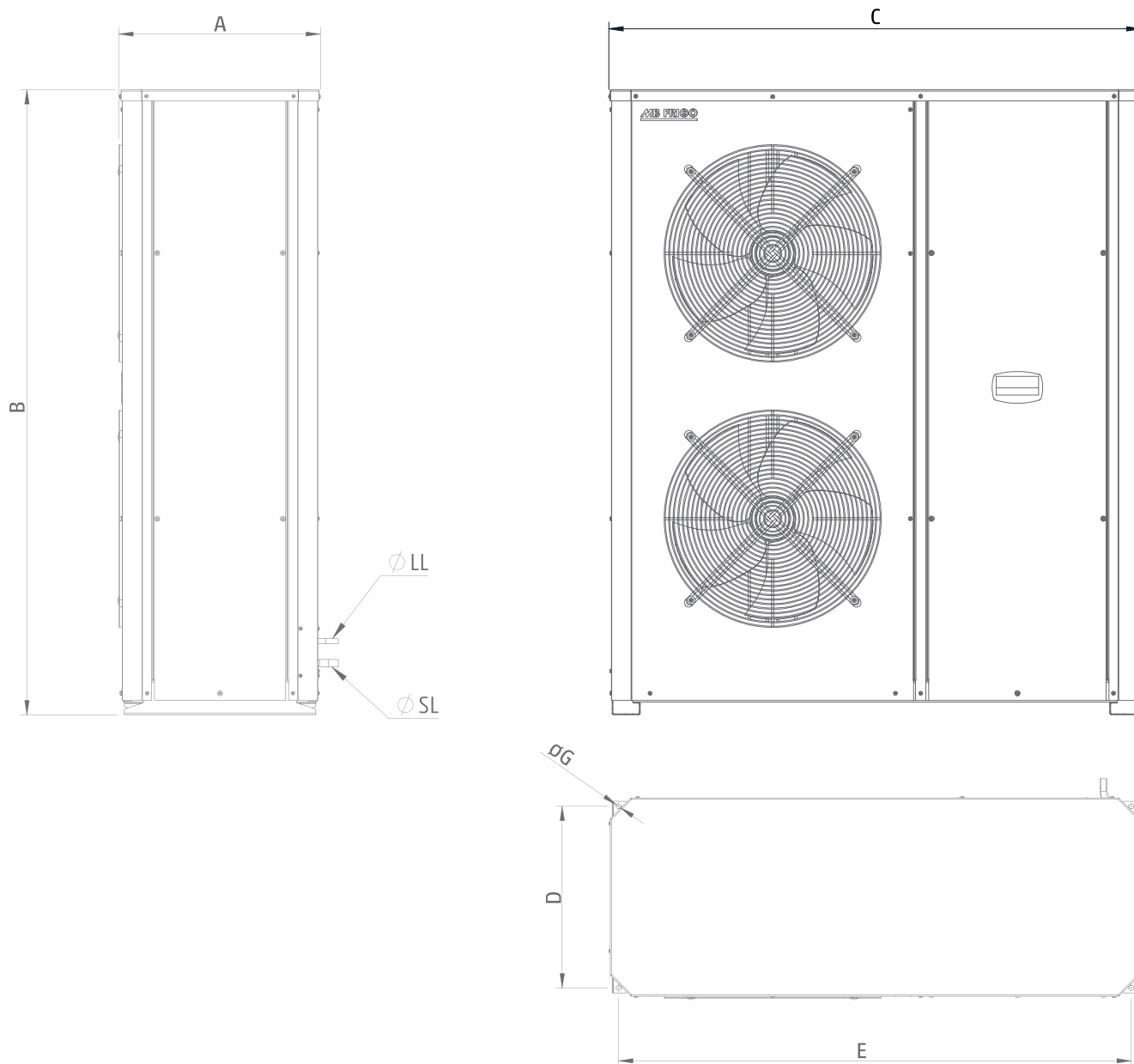

Refrigeration unit		Dimensions [mm]						Weight ⁴
MT Model	Type	A	B	C	D	E	G	[kg]
ArctiCO ₂ 100	AG-N3RU3PT9MT	446	1381	1176	400	1133	11	165

⁴ Units weights include protective housing, power supply and protection.

► REFRIGERATION UNIT:

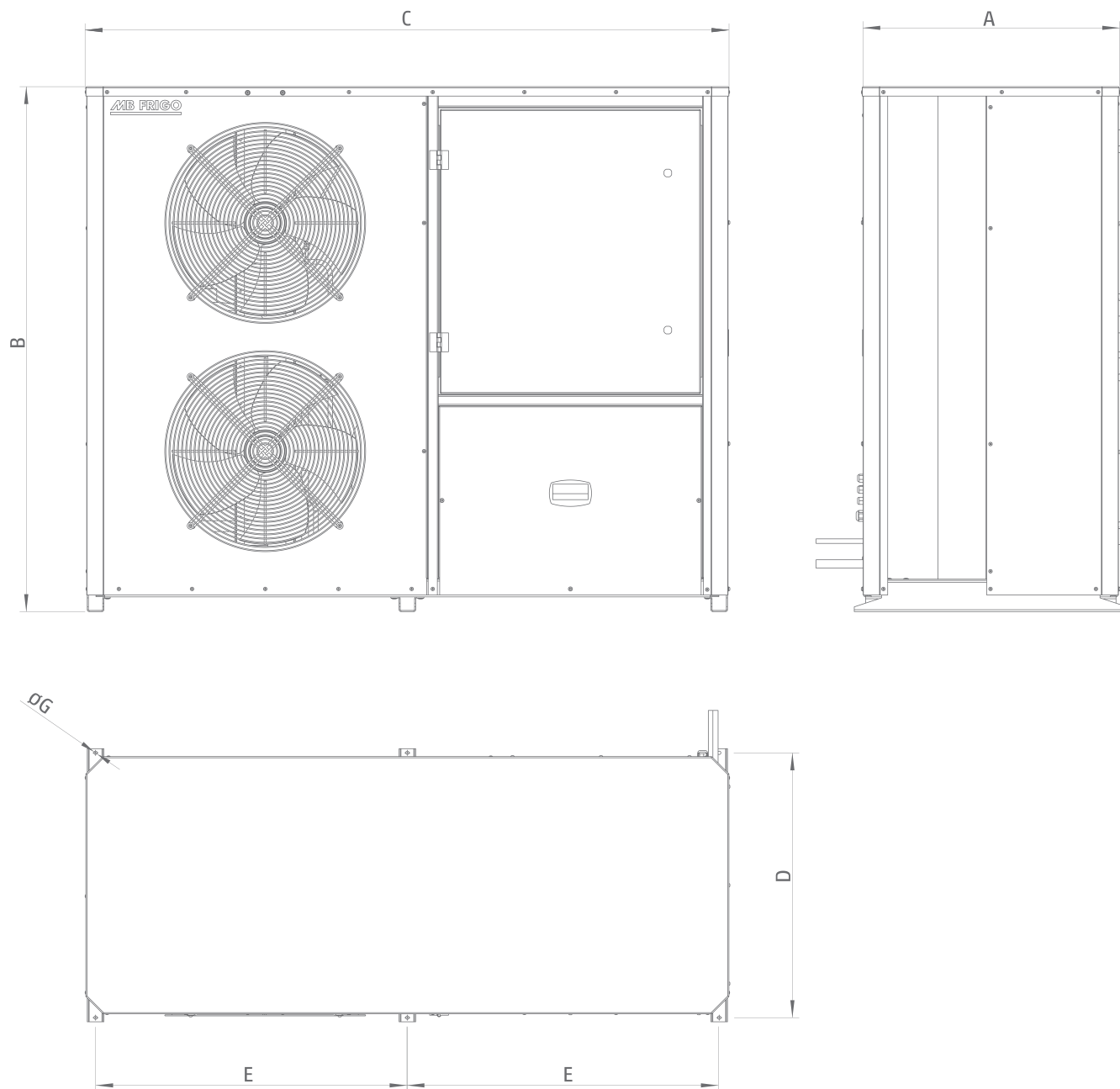

Refrigeration unit:		Dimensions [mm]						Weight ⁴
IT Model	Type	A	B	C	D	E	G	[kg]
ArctiCO ₂ 1200	AG-N6RU3PD9IT	725	1394	1712	703	828	11	530
ArctiCO ₂ 1500	AG-N6RU3PD12IT	725	1394	1712	703	828	11	530

⁴ Weight of units includes protective housing, power supply and protection.

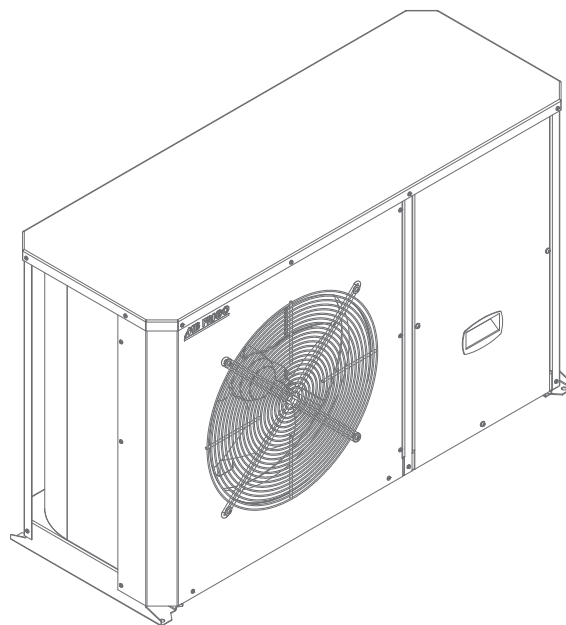
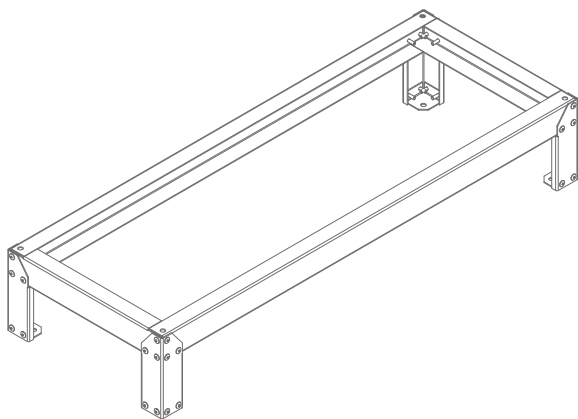

Housing group	A	B	C	D	E	F
N1, N2 i N3	1098	361	200	1173	436	11
N4	1275	476	200	1350	551	11

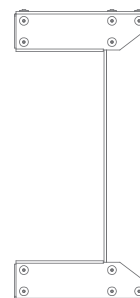
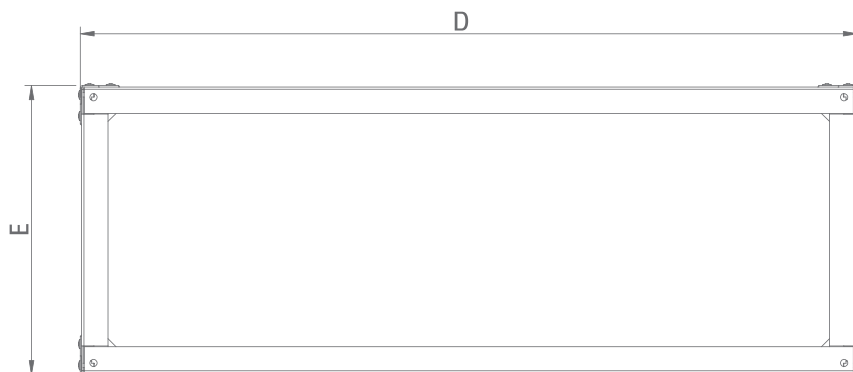
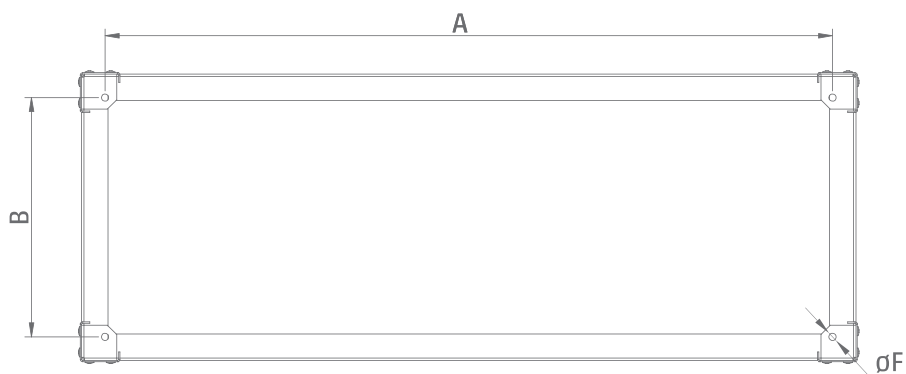

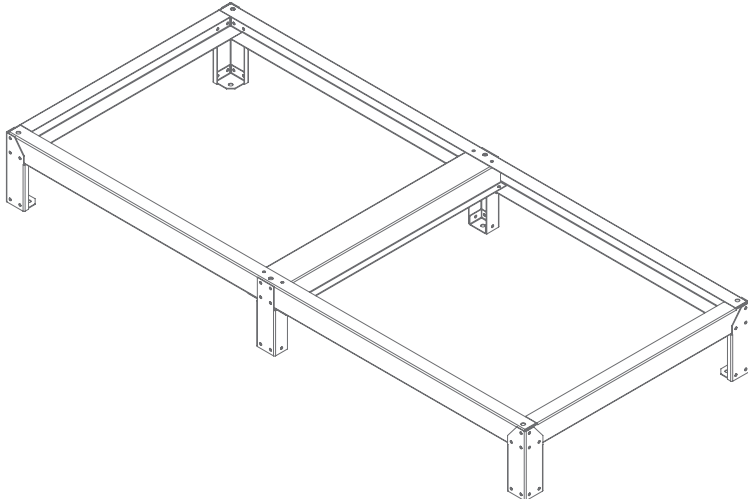

Housing group	A	B	C	D	E	F
N6	1629	663	200	1704	738	11

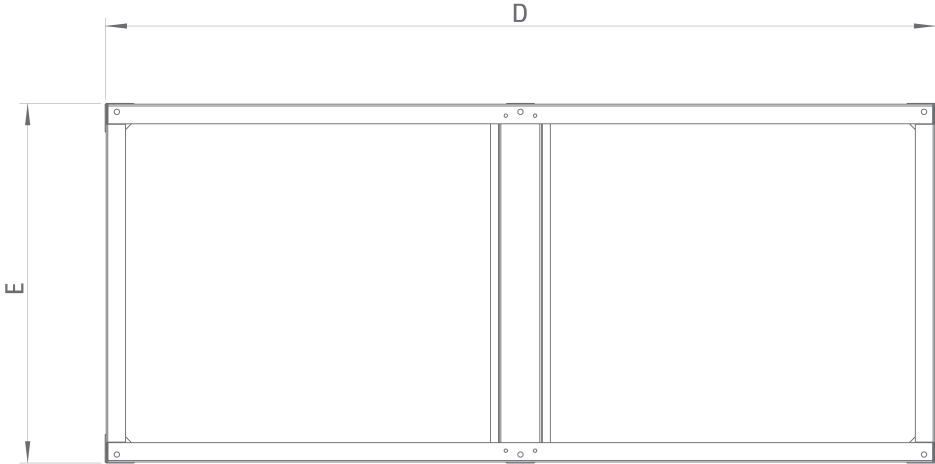
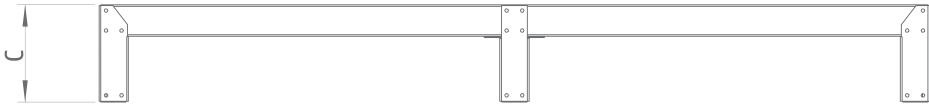
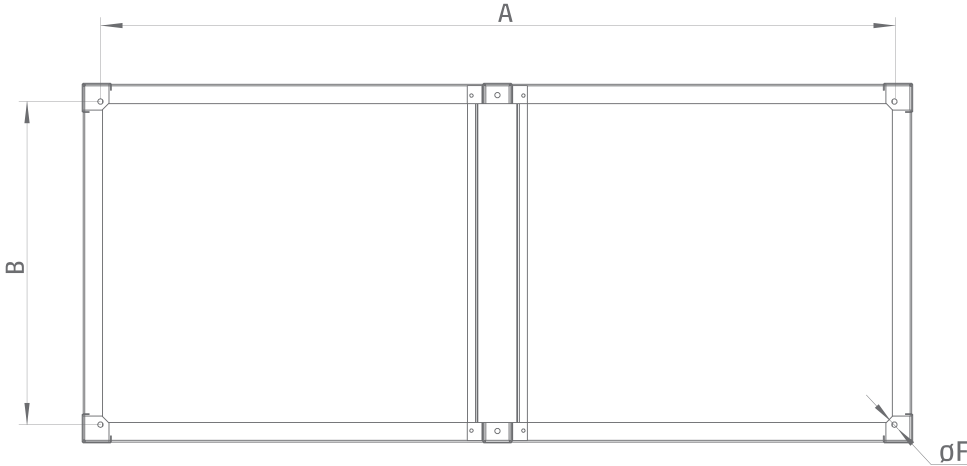

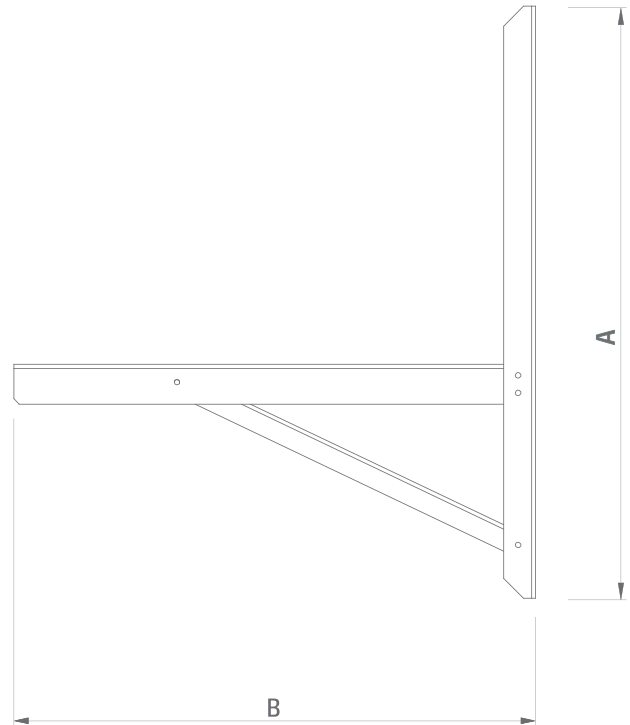
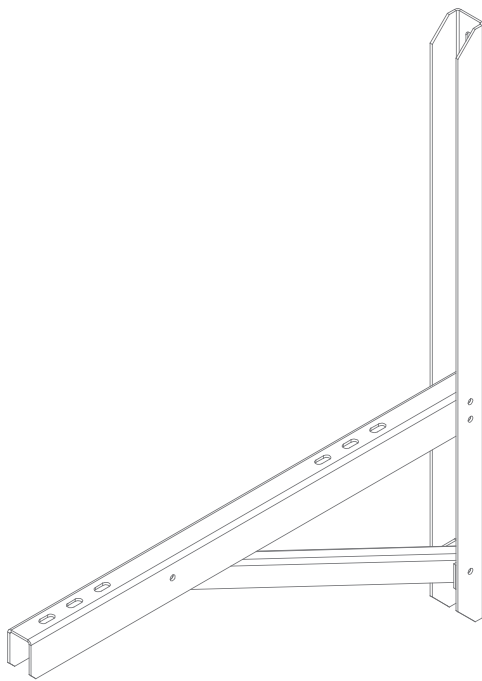

Housing group	Name	A	B	Slots
N1, N2 and N3	Bracket for the condensing unit (AE-Z1, Z2) 656 mm, painted sheet metal	744	656	Ø9x20

Dimensions are in millimeters (mm).

ARCTICO₂ MULTI

MULTICOMPRESSOR UNIT

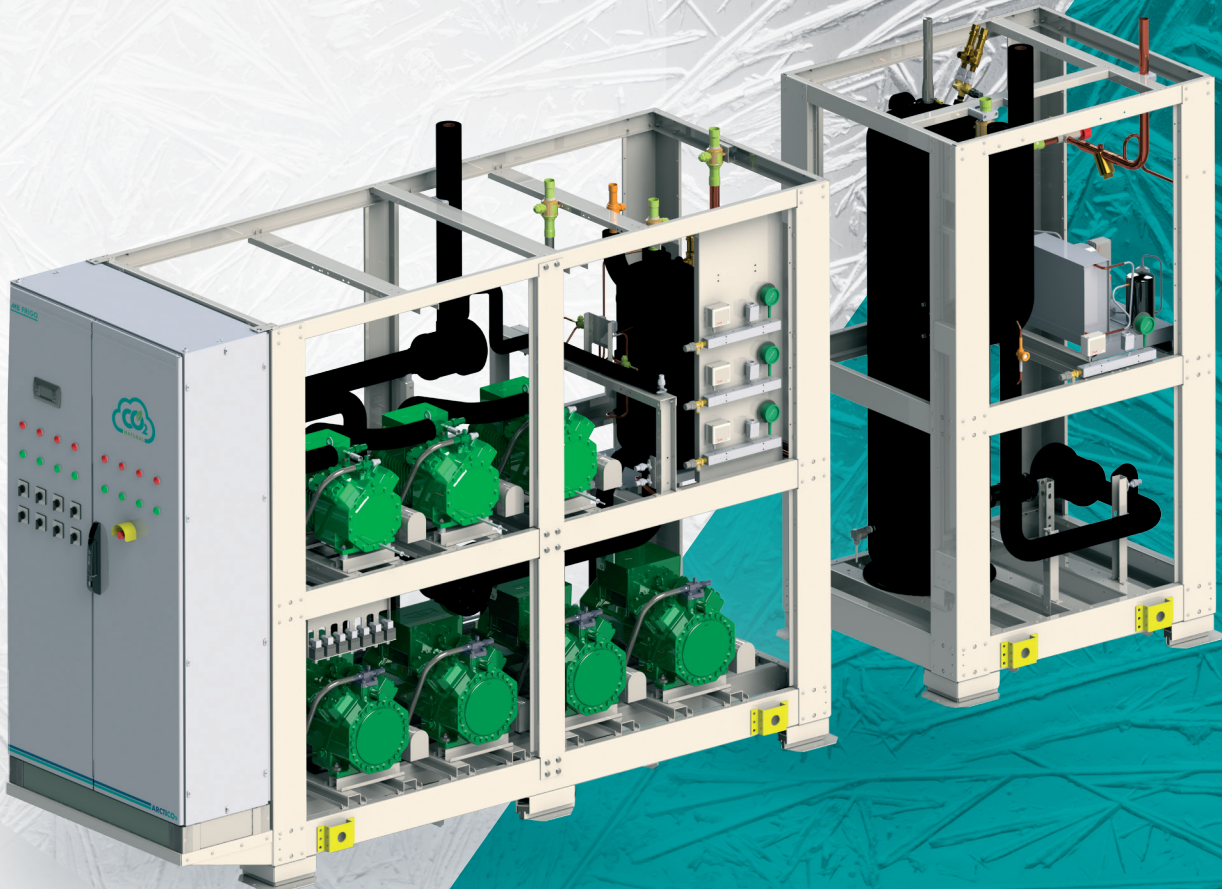

ARCTICO₂ MULTI

SPECIFIC SOLUTION

Multicompressor unit with natural refrigerant CO₂

Depending on the application, ARCTICO₂ MULTI is a standard or specific solution. They ensure energy-efficient cooling, superior quality control of products and raw materials, and energy savings.

With ARCTICO₂ Multicompressor units we provide a complete solution for cooling in industrial and commercial applications.

With **ARCTICO₂ Multicompressor** units we provide a complete solution for cooling in industrial and commercial applications using natural refrigerant. Depending on the application, we are able to produce custom made multicompressor units adapted to the project requirements.

In accordance with the environmental protection requirements, we have developed transcritical multicompressor units that are featured energy efficiency, operational safety, flexibility and a specific design.

For the needs of the application in supermarket chains, logistics and the food industry, we also provide CO₂ mini booster cooling units with 2 or 3 compressors and refrigeration capacity of up to 50 kW (MT and LT regimes), which are featured by reliability and very compact dimensions.

Our range also includes HFC alongside CO₂ multi-compressor refrigeration units.





MB FRIGO CHILLING
YOUR WORLD
SINCE 1981



Bani 81, 10010 Zagreb, Croatia
Tel: +385 1 660 8002, Fax: +385 1 660 9005
www.mbrigo.com

Scan to download vCard

